



### Features

- ULC Listed
- Self Restoring
- Complementary, low profile white exterior
- Mounts onto standard octagon or square box with trim plate
- Automatic reset

### Description

A neutral white exterior and an unobtrusive, low profile housing make the TD heat detector blend onto any ceiling. The plastic housing fits onto any standard octagon or square electrical box with a trim plate. The unit will protrude no more than 1" below the surface of the finishing ceiling.

Using a bi-metal disc as a heat sensing element, an alarm is initiated when the air temperature exceeds the unit's rated level. Only when the air temperature decreases below the rated level will the detector automatically reset.

### Specifications

The thermal detector shall be a Mircom Model TD 135 or TD 200 as appropriate. The unit shall be a fixed temperature self restoring type, designed for low profile mounting. The detector shall be constructed of neutral white, fire resistant thermoplastic material. Operation shall consist of the closing of N.O. contact to initiate an alarm detection circuit. When the air temperature returns below the detectors rating, the contact will return to the normal position.

Coverage: 225 Square feet.

Spacing: 15 feet centre, 7.5 feet from wall.

Note: The coverage and spacing figures given here are intended as a guide only. Heat detectors must always be spaced and installed as per the specific requirements outlined in the ULC codes as well as all other applicable national and local code requirements.



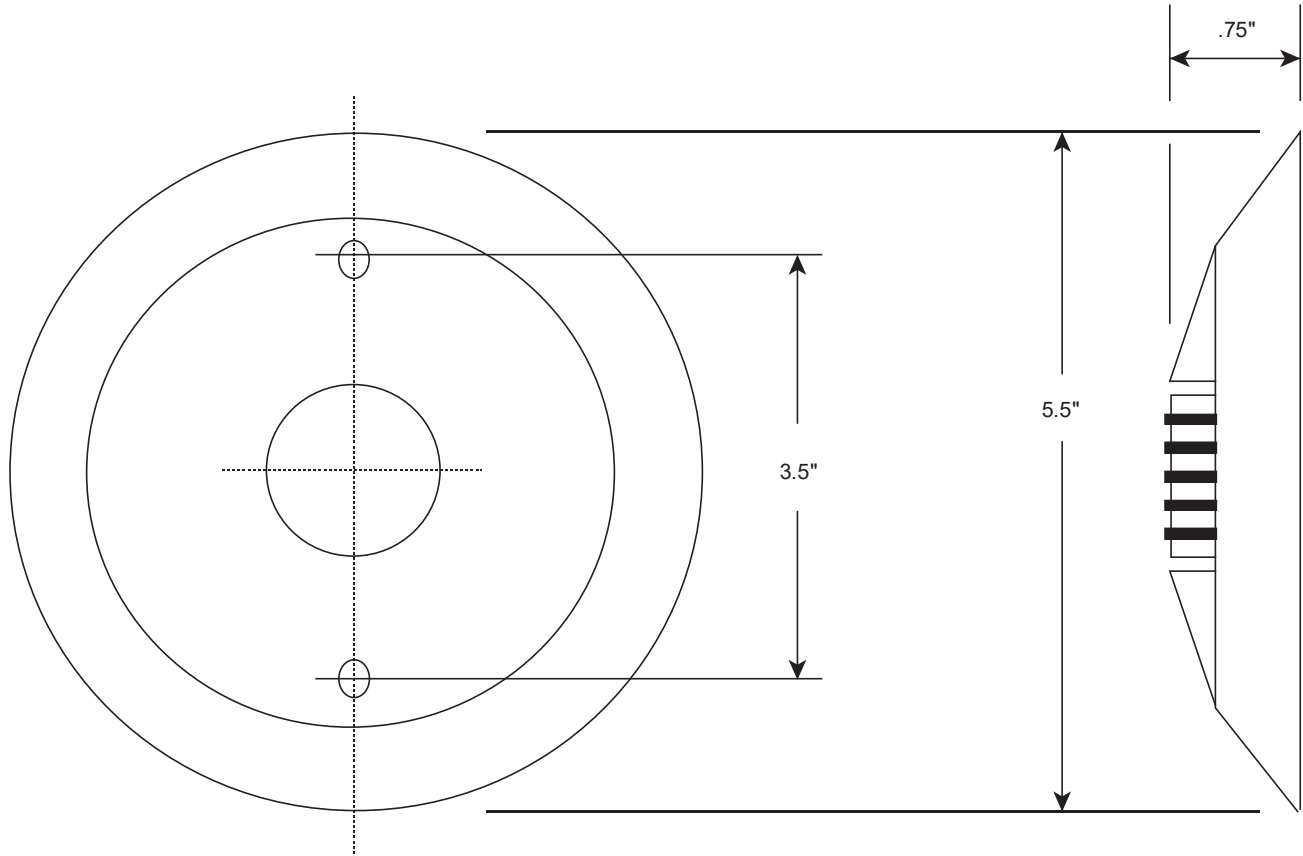

### Ordering Information

Model	Description
TD 135	Fixed Temperature 135°F (57°C) self restoring heat detector
TD 200	Fixed Temperature 200°F (94°C) self restoring heat detector

NOT TO BE USED FOR INSTALLATION PURPOSES.



**Canada**  
 25 Interchange Way  
 Vaughan, Ontario L4K 5W3  
 Telephone: (905) 660-4655  
 Fax: (905) 660-4113

**U.S.A.**  
 4575 Witmer Industrial Estates  
 Niagara Falls, NY 14305  
 Toll Free: (888) 660-4655  
 Fax Toll Free: (888) 660-4113

Web page: <http://www.mircom.com> Email: [mail@mircom.com](mailto:mail@mircom.com)

**Donde comprar:**

Ing Panama S.A  
[comercial@ingpanama.com](mailto:comercial@ingpanama.com)  
[www.ingpanama.com](http://www.ingpanama.com)

Distributed by:

ISO 9001:2008  
 REGISTERED

CAT. 5112  
 Rev. 5